



Eker 5

Inspired by the previous Eker range, NorStone builds up a new piece of furniture called Eker 5.

It assembles all of the sought aspects from a piece of furniture in this class. Its uncluttered design and its glossy black finish overcome the boundaries of refinement.

Combining stylishness and functionality, it will house easily all kind of electronic devices.



In the same range:
Eker 3



SPECIFICATIONS

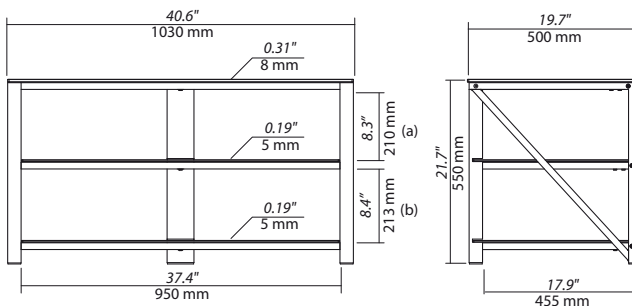
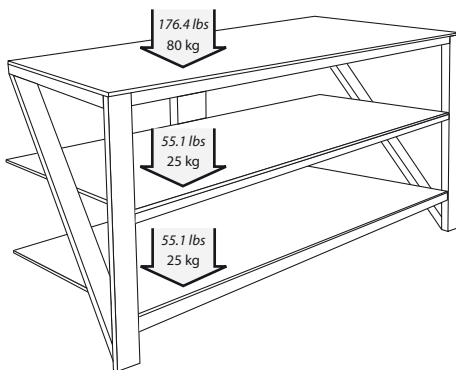

DESIGN

Finish: *Glossy Black/Black*

Structure: Black powder coated steel

Shelves: Black lacquered tempered glass

MAXIMUM LOAD

Upper shelf: 176.4 lbs / 80 kg

Internal shelves: 55.1 lbs / 25 kg

USABLE DIMENSIONS

Overall dimensions (W x H x D):

40.6" x 21.7" x 19.7" / 1030 x 550 x 500 mm

Upper shelf (W x D): 40.6" x 19.7" / 1030 x 500 mm

Internal shelves (W x D): 37.4" x 17.9" / 950 x 455 mm

Height between shelves: (a) 8.3" / 210 mm

(b) 8.4" / 213 mm

PACKAGING

Delivered disassembled with screws kit, mounting instructions and tools

Quantity/box: 1

Type: Brown cardboard

Dimensions (W x H x D):

44.5" x 3.9" x 24.2" / 1130 x 100 x 615 mm

Gross weight: 68.6 lbs / 31,1 kg

Net weight: 63,9 lbs / 29 kg

GenCode: 33760108801295

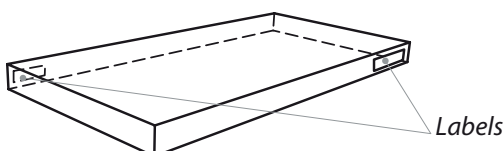

Labels