



In the same range:
Century

Century Stand

Ideal complement to the Century furniture, this speaker stand offers a resolutely universal design.

The Century line characteristics are dynamic shapes and a subtle miscegenation of materials. The alliance of stitched leather and white lacquered glass will bring a touch of a-temporal elegance.

Century Stand will enhance your speakers and ensure a stability which is essential for a good sound restitution.



SPECIFICATIONS

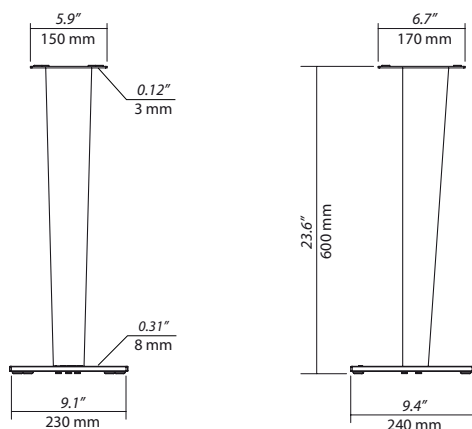
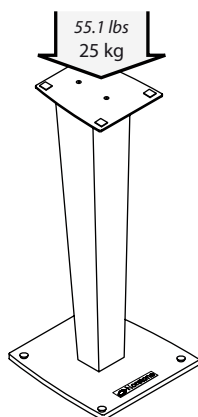

DESIGN

Finish: Black Leather/White

Structure: MDF and black leather with white stitching

Upper plate: Glossy black metal

Lower plate: White lacquered tempered glass

Miscellaneous: – Cable management system
– Rubber pads

MAXIMUM LOAD

Speaker stand: 55.1 lbs / 25 kg

USABLE DIMENSIONS

Overall dimensions (W x H x D):

9.1" x 23.6" x 9.4" / 230 x 600 x 240 mm

Upper plate (W x D): 5.9" x 6.7" / 150 x 170 mm

Lower base (W x D): 9.1" x 9.4" / 230 x 240 mm

PACKAGING

Delivered disassembled with screws kit, mounting instructions and tools

Quantity/box: 2

Type: White cardboard

Dimensions (W x H x D):

24.4" x 5.9" x 11.8" / 620 x 150 x 300 mm

Gross weight: 15.6 lbs / 7,1 kg

Net weight: 13.2 lbs / 6 kg

GenCode: 3760108801486

